

magnoplast

CATALOGUE

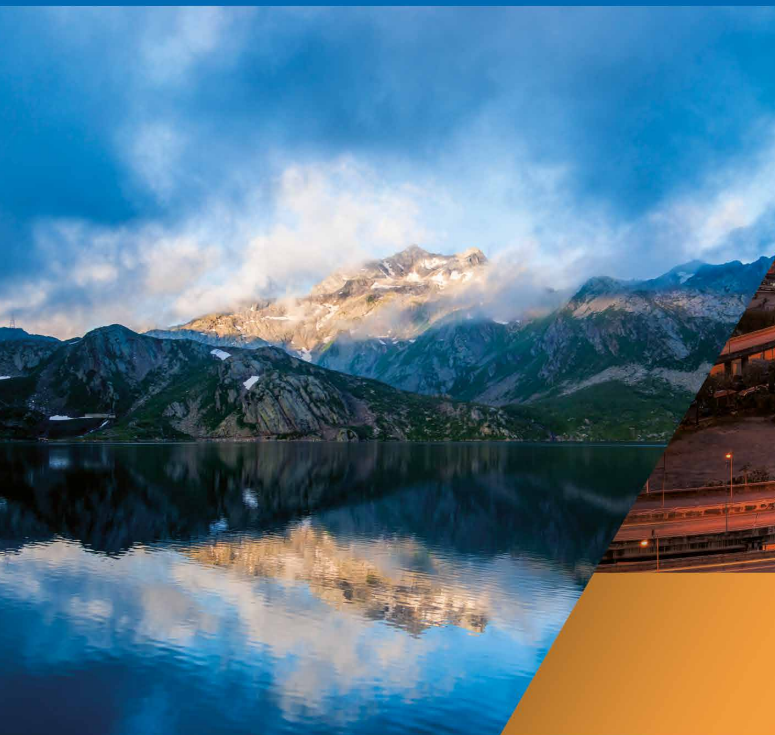

KG

**UNDERGROUND
SEWERAGE SYSTEM**

TABLE OF CONTENT:

System Advantages	5
Application	7
KG Product Catalogue	12
Design	22





**UNDERGROUND
SEWERAGE
SYSTEM**

KG



**DURABILITY OVER
100 YEARS**

CHARACTERISTICS OF KG PVC-U PRODUCTS

The advantages of KG PVC-U products include:

- completely resistant to general and pitting corrosion,
- resistant to harmful chemicals, whereas their external surfaces are resistant to the activity of subterranean waters,
- resistant to stray currents,
- very light weight,
- high wall smoothness,
- resistant to sediment forming on internal surfaces of the walls,
- reduced flow resistance during flow of wastewater,
- microbiological resistance,
- long operational life estimated to be around 100 years,
- fast and easy assembly,
- it can be combined easily with other materials.

MATERIAL PROPERTIES

Young's modulus	E (1 _{min}) 3 200 MPa
Average density	» 1,5 g/cm ³
Average linear coefficient of thermal expansion	» 0,08 mm/mK
Head conductivity	» 0,16 WK ⁻¹ m ⁻¹
Surface resistance	> 10 ¹² Ω
Poisson-factor	0,4

SEALS

In pipes, fittings and manholes elastomer KG seals are mounted by the factory. In adherence to the PN-EN 681-1 Polish standard the seals are made of styrenebutadiene rubber (SBR) or under the PN-EN 681-2 Polish standard they are made of thermoplastic elastomers (TPF) for KGUG pipe connectors for cast iron or alternatively oil and fat proof nitrile-butadiene rubber (NBR) seals are installed.

APPLICATION

KG system pipes and fittings have been designed to construct sewage system, as a rule, as non-pressure underground systems, which represent one of major buried utilities. Therefore one has always pay attention to solutions that offer good value for money i.e. they allow to boost investment value at the lowest possible cost. Such solution is the KG external sewage system with SC manholes system.

The tightness of connections of pipes, fittings and manholes provides for maximum pressure of 0.5 bar 5 m of water column at the temperature of 20°C. It is not possible to apply KG system pipes and fittings the temperature of flowing wastewater in pipes with diameters (DN) ranging form 110 to 200 exceeds constantly 60°C, and for pipes with diameters (DN) ranging from 250-500 it exceeds constantly 40°C. However, the instantaneous flow with the temperature of 75°C, is allowed.

The chemical resistance of pipes, fittings and seals is maintained for the wastewater with pH value from 2 to 12. When crude industrial wastewater flows, then regardless of pH value, the chemical resistance has to be checked in the ISO/TR 10358 Guidelines.



TECHNICAL REQUIREMENTS

To achieve superior quality of its products Magnaplast applies state-of-the-art raw materials, modern manufacturing processes and sealing systems with very resistant seals.

PIPE MARKING

On external surface of pipes permanent inscriptions are printed, every 1 running meter, containing at least the following information:

Manufacturer's name.	MAGNAPLAST
Standard No.	PN-EN 1401-1 or PN-EN 13476-2
application area symbol	U or UD
diameter size and wall thickness in mm	e.g.: KG DN 315 x 7.7
material symbol	PVC-U
nominal ring stiffness	e.g. SN4

Manufacturer data:

manufacturing line number	e.g.: M1
Date of manufacture	e.g.: 11 Sept. 2015

For instance: MAGNAPLAST Sp. z o.o. Sieniawa Źarska 69, 68-213 Lipinki Łużyckie, External sewage pipe PVC-U SN4 KG DN 160x4,0 1000mm (length) UD PN-EN 13476-2:2008 JoL No. 030, dated 2 Jan. 2015, date, time M bar code.



magnoplast Sp. z o.o. Sieniawa Źarska 69, 68-213 Lipinki Łużyckie 14041, 25.06.2013 KG DN 160-3,2 PVC-U SN2 UTB AT-15-7446/2012 z dn. 24.02.2012 M1 D.Z. N° 039 z dn. 12.03.2012

DELIVERY METHOD

All socket pipes and fittings are delivered with factory mounted KG lip seals. The KGUG and KGUS seals are ordered separately. The system components are delivered on special, designed for transport, pallets. Magnaplast Production Plan covers pipes in orange color with the diameters ranging from DN 110 to 500 mm. The pipes with smaller diameters, DN 110-200 mm, are used for the construction of sewer services lines. The pipes with higher diameters, DN 250-500 mm, are used mainly to construct sewage networks and are delivered as sections 2, 3 and 6 running meters long. The KGEM pipes having walls with foam core are delivered with ring stiffness SN2, SN4 and SN8. Meanwhile the KGEL pipes with solid walls fall into SN4 and SN8 ring stiffness categories. In addition to the pipes with sockets with standard length Magnaplast delivers pipes with elongated sockets (only SN8 pipes with solid walls), designed for the application in the areas with mining damages.

The PVC-U pipes made by Magnaplast, with smooth external and internal walls, are available as pipes with homogeneous solid wall (pursuant to EN 1401-1 European standard) or as pipes with walls having foam core (pursuant to the EN 13476-2 European standard or approval). The PVC-U pipes with smooth, homogeneous solid walls are made during extrusion process and are characterized by a homogeneous material in the overall pipe cross section. Meanwhile PVC-U pipes with smooth, foam core walls are made during co-extrusion process and have three layers. The external and internal layers of the wall are made of homogeneous material, whereas the middle layer contains foamed PVC-U material.

The PVC-U KG system piping for external sewer systems made by Magnaplast are marked with a symbol of area of application i.e. "U" and "UD". The standards for non-pressure, underground drainage and sewerage systems refer to the areas of applications with varied requirements:

- U:** this symbol applies to the area located at a distance higher than 1 m from the structure (except for the building structures), to which the underground piping system is connected,
- D:** this symbol applies to the area underneath the structure and at a distance smaller than 1 m (under the building structures), where pipes and fittings are laid in the ground and to which the sewage system discharges impurities and wastewater from the structure.

STANDARDS

Subject matter (systemic) standards

- applies to pipes and fittings with solid walls: **PN-EN 1401-1: 2009** Plastics Piping Systems For Non-pressure Underground Drainage And Sewerage. Unplasticized Poly(vinyl Chloride) (PVC-U) **Part 1: Specifications For Pipes, Fittings And The System**
- applies to the pipes with foamed inside walls: **PN-EN 13476: 2008** Plastic piping systems for non-pressure underground drainage and sewerage. Structured-wall piping systems of unplasticized poly(vinyl chloride) (PVC-U), polypropylene (PP) and polyethylene (PE)
Part 1: General Requirements And Performance Characteristics
Part 2: Specifications For Pipes And Fittings With Smooth Internal And External Surface And The System, Type A
- applies to manholes: **PN-EN 13598** Plastics piping systems for non-pressure underground drainage and sewerage. Unplasticized poly(vinyl chloride) (PVC-U), polypropylene (PP) and polyethylene (PE)
Part 1: 2011 - Specifications for ancillary fittings including shallow inspection chambers.
Part 2: 2009 - Specifications for manholes and inspection chambers in traffic areas and deep underground installations.
Part 3: 2013-12 – Recommendations on the conformity assessment

Standards comprising guidelines on pipe laying and their operation

PN-EN 1610: 2002/Ap1: 2007P

Construction And Testing Of Drains And Sewers

PN-ENV 1046: 2007

Plastics piping systems. System outside building structures to transfer water or waste water. Practice to install under the ground and above the ground.

PN-EN 476: 2012

General requirements for components used in drains and sewers.

PN-EN 752: 2008

Drain And Sewer Systems Outside Buildings

PN-EN 14654

Management And Control Of Operational Activities In Drain And Sewer Systems Outside Buildings

Part 1: 2014-07 - Cleaning

Part 2: 2013-06 - Rehabilitation

PN-B-10736: 1999

Earth Works The Water And Sewage Pipe Trends - Open Constructional Technical Requirements



**PRODUCT
CATALOGUE**

KG

TABLE OF CONTENT:

KGEM - socket pipes - co-extruded	13
KGEL - socket pipes - solid wall	15
KGB - bends	16
KGEA - branches	17
KGM - plugs	18
KGK - end caps	18
KGU - sleeves	19
KG-ERMM - double sockets	19
KGR - reducers	19
KGUS - connectors with stoneware pipes	20
KGUG - connectors with cast iron pipes	20
KGRE - access pipes	20
KGF - sleeve pipe for walls	21
Seals	21

PIPES WITH SOCKET - CO-EXTRUDED (KGEM) EN 13476

Class A - SN2

DN	d ₁ [mm]	s ₁ [mm]	D [mm]	t [mm]	L [mm]	Art. No.
160	160	3,2	183	110	500	22048
160	160	3,2	183	110	1000	22050
160	160	3,2	183	110	2000	22060
160	160	3,2	183	110	3000	22063
160	160	3,2	183	110	6000	22080
200	200	3,9	226	120	1000	23050
200	200	3,9	226	120	2000	23060
200	200	3,9	226	120	3000	23063
200	200	3,9	226	120	6000	23080

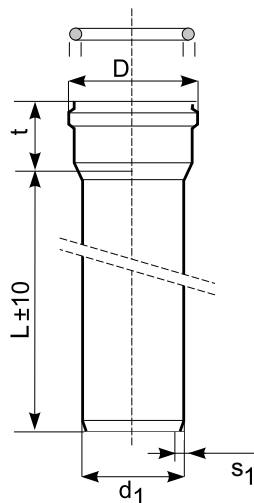

Class B - SN4

DN	d ₁ [mm]	s ₁ [mm]	D [mm]	t [mm]	L [mm]	Art. No.
110	110	3,2	128	76	500	20000
110	110	3,2	128	76	1000	20010
110	110	3,2	128	76	2000	20020
110	110	3,2	128	76	3000	20023
110	110	3,2	128	76	6000	20040
160	160	4,0	183	110	500	22000
160	160	4,0	183	110	1000	22010
160	160	4,0	183	110	2000	22020
160	160	4,0	183	110	3000	22023
160	160	4,0	183	110	6000	22040
200	200	4,9	226	120	500	23000
200	200	4,9	226	120	1000	23010
200	200	4,9	226	120	2000	23020
200	200	4,9	226	120	3000	23023
200	200	4,9	226	120	6000	23040
250	250	6,2	287	140	2000	24020
250	250	6,2	287	140	3000	24023
250	250	6,2	287	140	6000	24040
315	315	7,7	355	160	2000	25020
315	315	7,7	355	160	3000	25023
315	315	7,7	355	160	6000	25040
400	400	9,8	445	190	2000	26020
400	400	9,8	445	190	3000	26023
400	400	9,8	445	190	6000	26040

Class C - SN8

DN	d ₁ [mm]	s ₁ [mm]	D [mm]	t [mm]	L [mm]	Art. No.
110	110	3,2	128	76	500	20005
110	110	3,2	128	76	1000	20015
110	110	3,2	128	76	2000	20025
110	110	3,2	128	76	3000	20028
110	110	3,2	128	76	6000	20045
160	160	4,7	183	110	500	22005
160	160	4,7	183	110	1000	22015
160	160	4,7	183	110	2000	22025
160	160	4,7	183	110	3000	22028
160	160	4,7	183	110	6000	22045
200	200	5,9	226	120	1000	23015
200	200	5,9	226	120	2000	23025
200	200	5,9	226	120	3000	23028
200	200	5,9	226	120	6000	23045
250	250	7,3	287	140	2000	24025
250	250	7,3	287	140	3000	24028
250	250	7,3	287	140	6000	24045
315	315	9,2	355	160	2000	25025
315	315	9,2	355	160	3000	25028
315	315	9,2	355	160	6000	25045
400	400	11,7	445	190	2000	26025
400	400	11,7	445	190	3000	26028
400	400	11,7	445	190	6000	26045
500	500	14,6	567	220	3000	27028
500	500	14,6	567	220	6000	27045

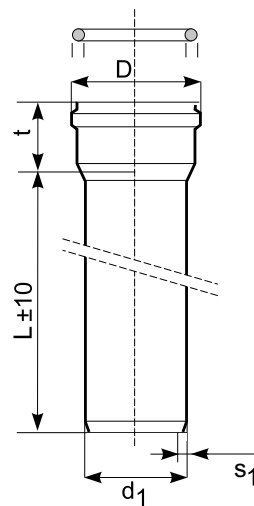

PIPES WITH SOCKET - SOLID WALL (KGEL) EN 1401

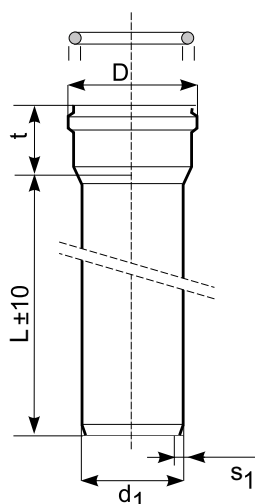

Class B - SN4

DN	d ₁ [mm]	s ₁ [mm]	D [mm]	t [mm]	L [mm]	Art. No.
160	160	4,0	183	110	1000	222010
160	160	4,0	183	110	2000	222020
160	160	4,0	183	110	3000	222023
160	160	4,0	183	110	6000	22040
200	200	4,9	226	120	1000	223010
200	200	4,9	226	120	2000	223020
200	200	4,9	226	120	3000	223023
200	200	4,9	226	120	6000	223040
250	250	6,2	287	140	3000	224023
250	250	6,2	287	140	6000	224040
315	315	7,7	355	160	3000	225023
315	315	7,7	355	160	6000	225040

Class C - SN8

DN	d ₁ [mm]	s ₁ [mm]	D [mm]	t [mm]	L [mm]	Art. No.
110	110	3,2	128	76	1000	220015
110	110	3,2	128	76	2000	220025
110	110	3,2	128	76	3000	220028
110	110	3,2	128	76	6000	220045
160	160	4,7	183	110	1000	222015
160	160	4,7	183	110	2000	222025
160	160	4,7	183	110	3000	222028
160	160	4,7	183	110	6000	222045
200	200	5,9	226	120	1000	223015
200	200	5,9	226	120	2000	223025
200	200	5,9	226	120	3000	223028
200	200	5,9	226	120	6000	223045
250	250	7,3	287	140	2000	224025
250	250	7,3	287	140	3000	224028
250	250	7,3	287	140	6000	224045
315	315	9,2	355	160	2000	225025
315	315	9,2	355	160	3000	225028
315	315	9,2	355	160	6000	225045
400	400	11,7	445	190	2000	226025
400	400	11,7	445	190	3000	226028
400	400	11,7	445	190	6000	226045
500	500	14,6	567	220	3000	227028
500	500	14,6	567	220	6000	227045

BENDS (KGB)

DN	angle	z ₁ [mm]	L [mm]	Art. No.
110	15°	8	84	20100
110	30°	14	85	20110
110	45°	29	85	20120
110	67°	40	104	20130
110	87°	69	123	20140
160	15°	32	88	22100
160	30°	40	135	22110
160	45°	47	135	22120
160	67°	96	170	22130
160	87°	64	142	22140
200	15°	26	133	23100
200	30°	49	160	23110
200	45°	65	160	23120
200	67°	68	168	23130
200	87°	105	245	23140
250	15°	19	170	24100
250	30°	37	189	24110
250	45°	57	189	24120
250	87°	132	283	24130
315	15°	23	198	25100
315	30°	47	221	25110
315	45°	72	221	25120
315	87°	166	340	25130
400	15°	29	238	26100
400	30°	59	268	26110
400	45°	91	268	26120
400	87°	211	419	26130
500	15°	37	279	27100
500	30°	74	317	27110
500	45°	114	317	27120
500	87°	263	506	27130

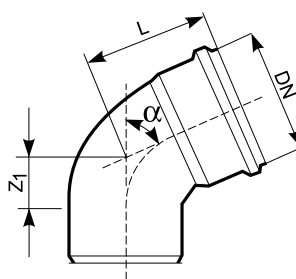

BRANCHES (KGEA)

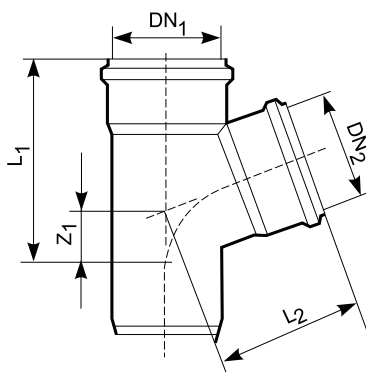

DN1/ DN2	angle	z ₁ [mm]	L ₁ [mm]	L ₂ [mm]	Art. No.
110/110	45°	27	226	201	20300
160/110	45°	16	244	252	20330
160/160	45°	38	317	283	20350
200/110	45°	17	280	271	20360
200/160	45°	20	337	327	20380
200/200	45°	46	402	359	20390
250/110	45°	30	394	294	22300
250/160	45°	33	472	396	22320
250/200	45°	48	397	396	22330
250/250	45°	50	560	530	22340
315/110	45°	34	371	407	23300
315/160	45°	15	415	395	23320
315/200	45°	5	457	438	23330
315/250	45°	15	650	515	23340
315/315	45°	45	645	600	23350
400/160	45°	7	563	488	24320
400/200	45°	8	540	521	24330
400/250	45°	95	905	620	24340
400/315	45°	9	817	680	24350
400/400	45°	14	878	740	24360
500/160	45°	112	480	520	25320
500/200	45°	85	534	561	25330
500/250	45°	34	734	720	25340
500/315	45°	38	888	770	25350
500/400	45°	52	927	870	25360
110/110	87°	55	186	142	21300
160/110	87°	83	240	178	21330
160/160	87°	116	297	213	21350
200/110	87°	109	304	166	21360
200/160	87°	143	352	216	21380
200/200	87°	144	381	230	21390
250/110	87°	62	317	256	22305
250/160	87°	88	388	285	22325
250/200	87°	107	422	310	22335
250/250	87°	115	439	345	22345
315/110	87°	67	352	266	23305
315/160	87°	90	415	315	23325
315/200	87°	100	450	340	23335
315/250	87°	115	480	380	23345
315/315	87°	135	525	430	23355
400/160	87°	80	465	415	24325
400/200	87°	95	495	438	24335
400/250	87°	120	535	465	24345
400/315	87°	145	585	490	24355
400/400	87°	180	640	530	24365
500/160	87°	205	640	390	25325
500/200	87°	220	665	415	25335
500/250	87°	230	690	450	25345
500/315	87°	260	765	500	25355
500/400	87°	295	845	555	25365

PLUGS (KGM)

DN	L [mm]	D [mm]	Art. No.
110	32	120	20220
160	42	170	22220
200	50	217	23220
250	80	265	24220
315	80	333	25220
400	80	423	26220
500	80	525	27220

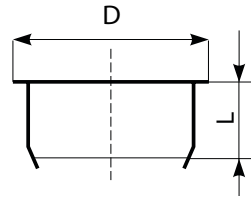

END CAPS (K GK)

DN	L [mm]	Art. No.
110	43	20240
160	52	22240
200	64	23240
250	68	24240
315	77	25240
400	90	26240

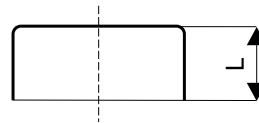

SLEEVES (K GU)

DN	L [mm]	Art. No.
110	105	20180
160	138	22180
200	215	23180
250	250	24180
315	293	25180
400	324	26180
500	380	27180

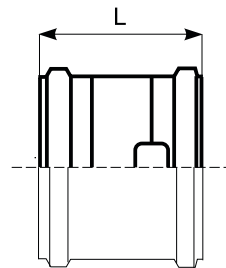

DOUBLE SOCKETS (KG-ERMM)

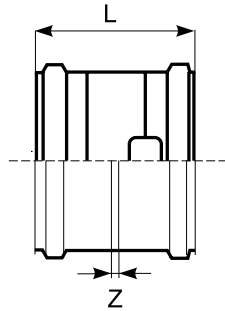

DN	Z [mm]	L [mm]	Art. No.
110	3	105	20200
160	3	138	22200
200	5	215	23200
250	7	250	24200

REDUCERS (KGR)

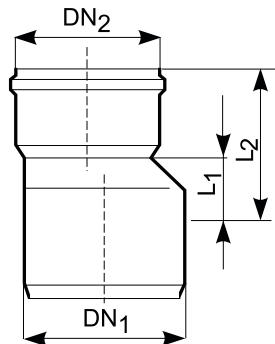

DN1/DN2	L ₁ [mm]	L ₂ [mm]	Art. No.
160/110	46	118	21280
200/160	48	143	23280
250/200	147	264	24280
315/250	214	342	25280
400/315	243	385	26280
500/400	150	340	27280

MULTI-STAGE REDUCTIONS (KGR)

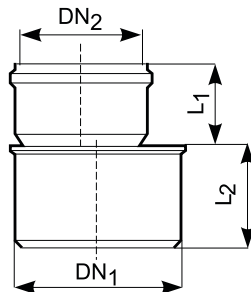

DN1/DN2	L ₁ [mm]	L ₂ [mm]	Art. No.
250/160	113	130	24283
315/160	113	141	25283
315/200	118	147	25284

CONNECTORS WITH STONEWARE PIPES (KGUS)

DN	D [mm]	L [mm]	Art. No.
110	138	151	20410
160	194	207	22410
200	250	248	23410

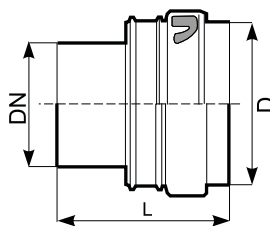

DN	D [mm]	L [mm]	Art. No.
250*	315	283	24400
315*	400	318	25400

* for the connector with the stoneware pipes KGUS 250 and 315 KGUS seal has to be ordered separately

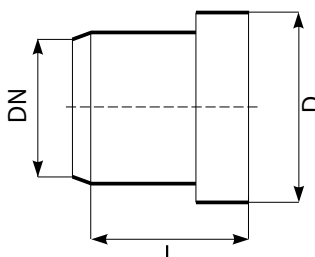

CONNECTORS FOR CAST IRON PIPES (KGUG)

DN	d ₁ [mm]	L [mm]	Art. No.
110**	124	60	20440
160**	187	98	22440
200**	242	103	23440

** to the connector with cast iron pipes KGUG DN 110-200 KGUG seal has to be ordered separately

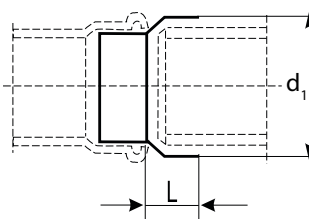

ACCESS PIPES - LOCKING PLATE (KGRE)

DN	Z ₁ [mm]	L [mm]	Art. No.
110	58	179	20160
250	128	722	24160

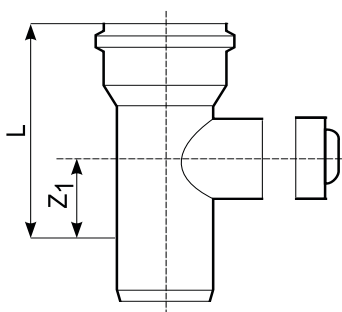

ACCESS PIPES - COVER WITH BOLTS (KGRE)

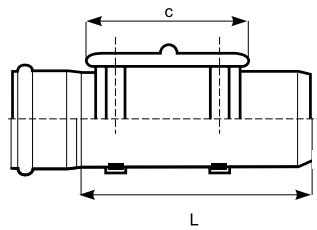

DN	c	L [mm]	Art. No.
110	221	279	20161
160	282	332	22160
200	394	494	23160

WALL SLEEVES (KGF)

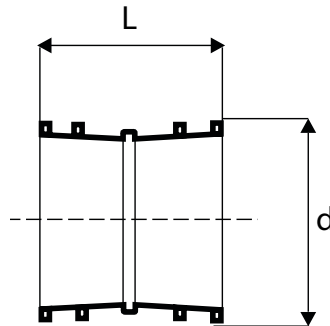

DN	L [mm]	d [mm]	Art. No.
110	110	131	20600
160	110	184	22600
200	110	226	23600
250	110	286	24600
315	110	354	25600
400	110	440	26600
110	240	137	20620
160	240	190	22620
200	240	231,5	23620
250	240	290	24620
315	240	359	25620
400	240	448	26620
500	240	554	27620

SEALS



Pipes	DN	Art. No.
KG	110	7200
KG	160	7220
KG	200	7230
KG	250	7240
KG	315	7250
KG	400	7260
KG	500	7270
cast iron connectors		
KGUG	110	20460
KGUG	160	22460
KGUG	200	23460
connectors to stoneware pipes		
KGUS	250	24500
KGUS	315	25500



HYDRAULIC DIMENSIONING OF PVC-U SEWAGE PIPES

The hydraulic calculations for sewage pipe sections will involve determination of their diameters, heights of wastewater filling and flow rates. The calculations are made on the basis of computational flow rate and assumed pipe bottom inclination absolute roughness of pipe walls under the assumption that:

- size,
- pipe shape, its inclination,
- roughness and assumed computational flow at the overall computational length of the pipe remain constant,
- flow rates are identical at all points of flux section.

The hydraulic calculations for sewage pipe sections will involve determination of their diameters, heights of wastewater filling and flow rates. The calculations are made on the basis of computational flow rate and assumed pipe bottom inclination absolute roughness of pipe walls under the assumption that:

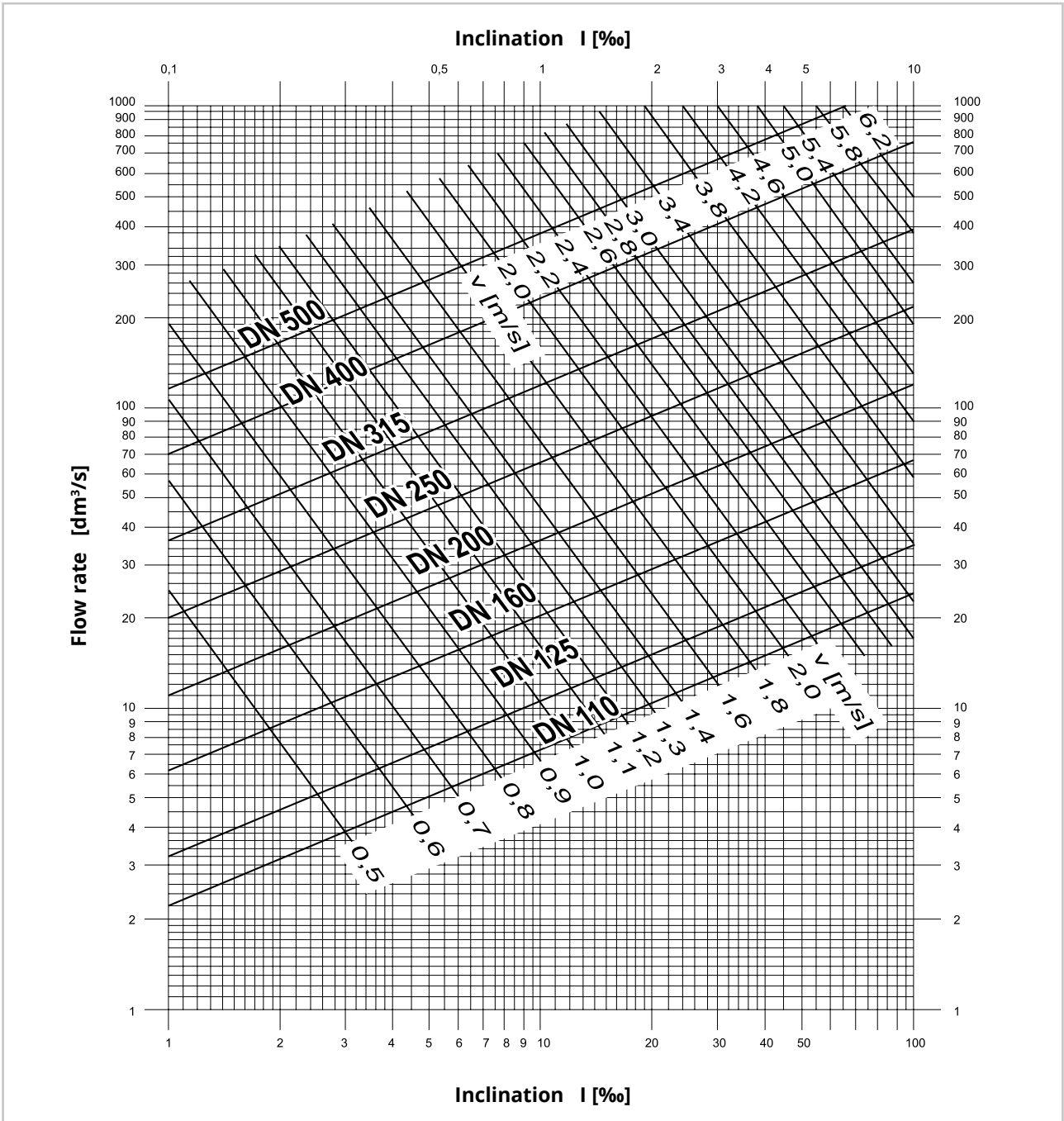

Fig. 2. Nomogram for hydraulic calculations with sewage pipe full filled.

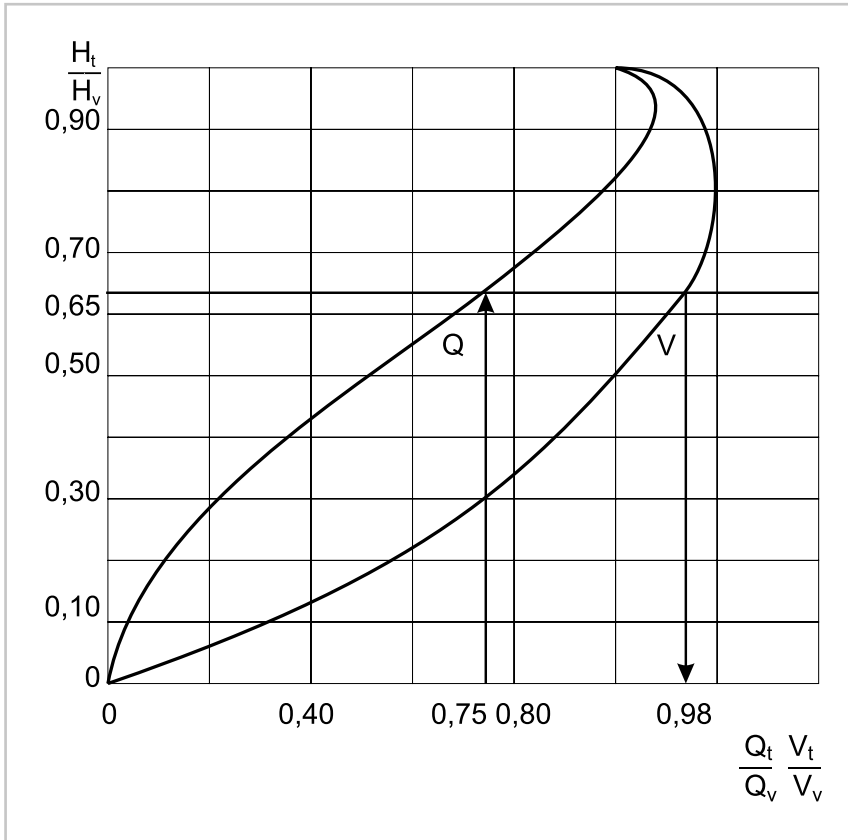

Fig. 3.

Efficiency curve Q and V

The basic parameter for selection of sewage pipe inclination is safeguarding self-cleaning conditions i.e. to obtain in the sewage pipes the lowest flow rate that prevents sedimentation process at pipe bottom. Flow rates meeting the requirement of self-cleaning when the pipe is completely filled should not be smaller than:

V = 0.8 m/s - for sanitary sewage system,

V = 0.6 m/s - for stormwater drainage system,

V = 1.0 m/s - for combined sewage system.

The flow rates should not be treated at constant, but dependent on the pipe diameter and should grow together with the diameter.

To comply with the above requirement, the minimum inclinations of pipes can be assumed as $I_{\min} = 1/d$, where d is an internal diameter [mm].

Diameter DN [mm]	sanitary sewerage system $V_{min} = 0.8$ [m/s]		stormwater drainage system $V_{min} = 0.6$ [m/s]		combined sewage system $V = 1.0$ [m/s]	
	inclination I [‰]					
	k = 0,4	k = 0,25	k = 0,4	k = 0,25	k = 0,4	k = 0,25
160	6,0	4,5	3,4	2,7	9,5	6,5
200	3,4	3,5	2,5	2,0	7,0	5,2
250	3,4	2,6	1,8	1,5	5,2	4,0
315	2,5	2,0	1,4	1,2	4,0	3,0
400	2,0	1,5	1,0	0,85	3,0	2,3

Tab. 3. Minimum inclinations I [‰] of PVC-U sewage pipes

When designing sewage system, owing to a need of appropriate venting of pipes, the rule should be followed that even with maximum flows the pipe should not be completely filled.

Diameter DN [mm]	Maximum inclination I [%] at maximum flow rate	
	Sanitary sewage system $V_{max} = 5.0$ [m/s]	Stormwater drainage system and combined sewage system $V_{max} = 7.0$ [m/s]
200	23,0	45,1
250	16,8	32,9
315	13,3	28,0
400	9,0	17,7
500	6,8	13,3

Tab. 4. Approximate values of maximum inclinations of sewage pipes under the assumption of maximum flow rates.

DN [mm]	d^* [mm]	h_n/d	h_n [cm]
110	104,0	0,6	6,0
125	119,0	0,6	7,2
160	152,8	0,6	9,0
200	191,0	0,6	11,0
250	237,8	0,6	14,0
315	299,6	0,6	18,0
400	380,4	0,7	26,0
500	475,6	0,7	35,0

(*) - inside diameter of SN4 class pipe (SDR 41)

Tab. 5. Recommended filling h_n of circular sewage pipes with internal diameter d at Q_{max}

For instance:

For a certain flow rate of wastewater $Q_1 = 40 \text{ dm}^3/\text{s}$ and inclination of pipe bottom $i = 2\%$ using nomogram one has to select pipe diameter under the assumption of complete filling DN200mm and then numerical value for such flow has to be read out $Q_v = 53 \text{ dm}^3/\text{s}$ along with flow rate $V_v = 1.8 \text{ m/s}$. Then Q_1 to Q_v ratio should be calculated: $40/53 = 0.75$ using the efficiency curve Q (Fig. 3) then filling $H/\text{DN} = 0.65$ has to be read out, thus filling $H_1 = 0.65 \times 20 = 13 \text{ cm}$. For a certain filling to diameter ratio the value of V_1 to V_v ratio equal to 1,16 has to be read on the efficiency curve V, and velocity has to be calculated for the flow $Q_1 = 40 \text{ dm}^3/\text{s}$. $V_1 = 1,8 \times 1.16 = 2.0 \text{ m/s}$.



SOLUTIONS FOR YEARS

magnoplast



HTPLUS INDOOR SEWAGE SYSTEM



ULTRA dB LOW-NOISE INDOOR SEWAGE SYSTEM



SKOLAN-dB THICK-WALLED, LOW-NOISE SEWAGE SYSTEM



KG PVC OUTDOOR SEWERAGE SYSTEM



PP OUTDOOR SEWERAGE SYSTEM MAGNACOR



SEWERAGE CHAMBERS SYSTEM

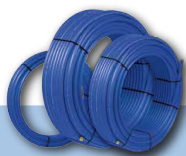

POLYETHYLENE (PE) PRESSURE PIPES



DRAINAGE (DR) SYSTEMS